

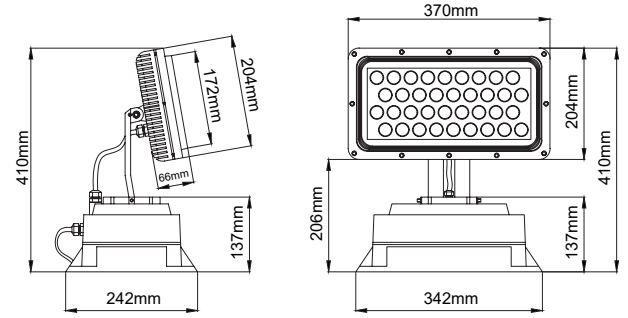

- Direct lighting luminaire for use with LEDs.
- Corrosion resistant die-cast aluminium body.
- Installation with bracket on floor, walls and ceiling surfaces.
- Mains voltage: 220-240V / 50-60Hz.
- Clever thermal design.
- Spot, medium and wide beam angles available.
- Led colour temperatures are Red, Green, Blue and Amber.
- Suitable for illumination up to 20 meter height.
- Optionally 2 cable entries for through-wiring of mains supply cable.
- Internal silicon gaskets ensure IP protection.
- All external screws are stainless steel.
- Double layer polyester powder paint resistant to corrosion and salt spray fog.
- Up to 138lm/W efficiency.
- High colour consistency: <3 SDCM
- Stainless steel cable gland and mains cable provided with IP68 socket.
- Mechanical aiming lock.
- DALI and 1-10V dimming options available.

## Dimensions



## Light Distribution

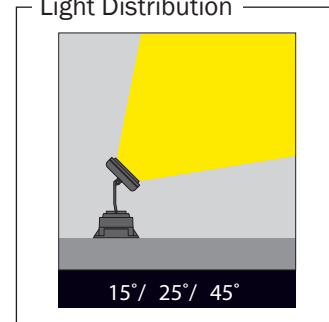

## Galaxy RGB / LGT.110.104

Item Code	LGT.110.104.11
Light Color Source	1W High Power LED / 1W Power LED
LED Quantity	Red12, Green12, Blue12
Beam Angle	10°/25°/55°
Digital Interface	Standard DMX protocol
Connector	3-pin signal connector /

