

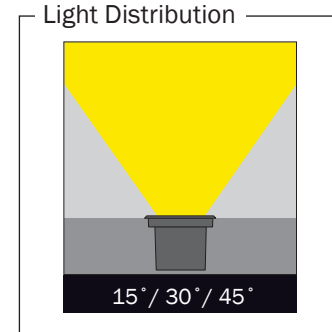

- Die-Cast Aluminium body.
- 316 grade stainless steel frame.
- Installation with plastic outer housing.
- Outer key enables fitting to tilt without opening inside.
- Mains voltage: 220-240V / 50-60Hz.
- Spot, medium and wide beam angles available.
- Max. Weight resistance : 2000KG
- Convenient to be used with COB led.
- Led colour temperatures are optionally 2700K, 3000K, 3500K, 4000K and 5000K.
- Thermal shock resistant safety glass.
- Weatherproof and durable silicone rubber gasket.
- All external screws are stainless steel.
- High colour consistency: <3 SDCM
- Up to 135lm/W efficiency.

Dimensions

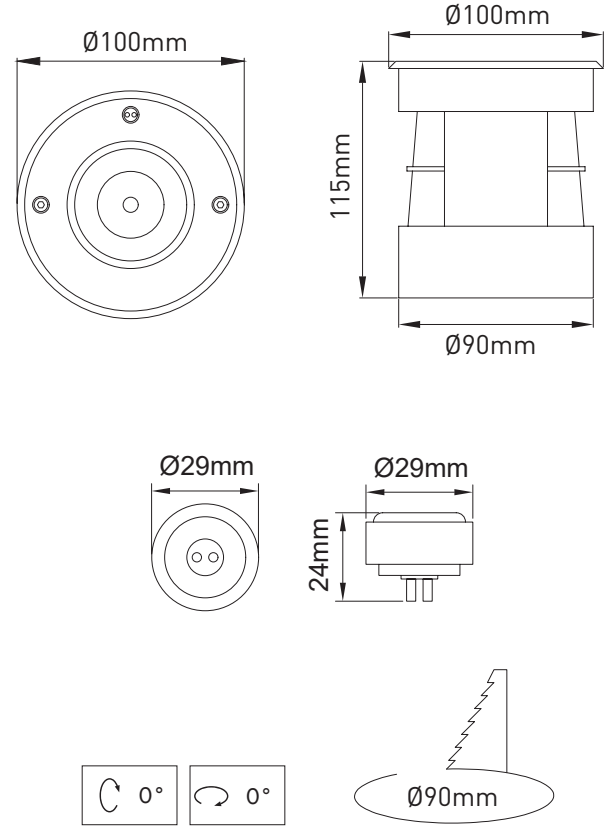

Meteor-S/ [LGT.120.101](#)

Order Code	System Power	Kelvin / Color	Lumen Output	Dali Dimming Opt.	1-10V Dali Dimming Opt
LGT.120.101.10	3W	2700K	381	✓	✓
LGT.120.101.11	3W	3000K	389	✓	✓
LGT.120.101.12	3W	3500K	397	✓	✓
LGT.120.101.13	3W	4000K	405	✓	✓
LGT.120.101.14	3W	5000K	417	✓	✓